

无锡萨科特新能源科技有限公司(文件)

Conventional Single Glass Module Installation and Maintenance Manual

文件编号 DOCUMENT NO.	SKT/03-GT-015-202 1	编制 COMPILER	王晶晶 Chenshuilin
文件版本 EDITION	A/2[2021]	审核 REVIEWER	封俊杰 Yuan Huazhi
分发编号 DISTRIBUTION NO.		批准 APPROVER	蔡文祥 Wang Shengjian
受控状态 STATUS	盖章处 <i>STAMP</i>		

本文件全部条文内容（含封面）共*29*页

THIS DOCUMENT HAS A TOTAL OF *29* PAGES INCLUDING THE FRONT COVER

发布日期 ISSUE DATE 2021-01-01

实施日期 IMPLEMENTATION DATE

2021-01-01

2021. 【8G】

① PURPOSE

This manual provides information on the installation and safe use of photovoltaic modules manufactured by Wuxi Sunket New Energy Technology Co. Ltd. (Abbreviated as “Wuxi Sunket” or “Sunket”) and recommends safe and reliable installation instructions and module maintenance.

Before installation, the installer must read and understand this manual, and if any questions, please contact Sunket’s sales or customer service personnel for further information. During the installation, the installer should comply with all safety precautions in this manual and the relevant legal norms for the installation and should be familiar with the mechanical loads and electrical requirements of the installed system. In case of damage to the product due to construction or defects in design of the power generation system, Sunket has the right to refuse compensation.

② SCOPE

This document is applicable to the installation of conventional single-glass modules of Wuxi Sunket New Energy Technology Co. Ltd.

③ OBLIGATIONS

Module Technology Department: responsible for document preparation, updating and maintenance.

④ REFERENCES

None

⑤ DEFINITIONS

None

⑥ PROCEDURE

None

⑦ RELEVANT RECORDS AND SHEETS

Refer to document curriculum vitae

⑧ SUPPLEMENTARY PROVISIONS

The final interpretation is the responsibility of the Module Technology Department, and the document is invalid without controlled stamp or missing. It is forbidden for any department or individual to occur private printing, copying, reproduction and other acts that infringe upon the controlled management of the document. The document is translated from Chinese to English, so if there is any inconsistency, the Chinese version shall prevail.

Wuxi Sunket New Energy Technology Co.,Ltd.	Conventional Single Glass Module	SUNKET SOLAR
Dominant Sector: Module Technology Platform	Installation and Maintenance Manual	Page: page 3 of 33

CONTENTS

1	Installation manual instructions	5
2	Sunket PV modules and applications	5
3	Warning	6
4	Safety instructions	6
5	Unloading, transport and storage	10
5.1	Packing Box sign instructions	10
5.2	Unloading Notes	11
5.3	Secondary transportation and precautions	12
5.4	Storage	
13		
5.5	Module sign instructions	14
6	Unpacking	
14		
7	Module Installation	
15		
7.1	Environmental conditions and installation address selection	15
7.2	Photovoltaic module installation inclination	16
8	Installation instruction	17
8.1	Bolt fixing method	18
8.2	Pressing block fixing method	20
8.3	Connection Method of split junction box assembly cable wires (recommended connection)	
24		
9	Electrical installation and connection	25
9.1	Bypass Diode	28
10	Grounding	
28		
11	Module inspection and maintenance	30

Wuxi Sunket New Energy Technology Co.,Ltd.	Conventional Single Glass Module	SUNKET SOLAR
Dominant Sector: Module Technology Platform	Installation and Maintenance Manual	Page: page 4 of 33

11.1	Module appearance check and replacement.....	30
11.2	Cleaning.....	31
12	Troubleshooting	
33		
13	Disclaimer	
33		

1 Installation manual instructions

Thank you very much for choosing photovoltaic module products from Wuxi Sunket New Energy Technology Co. Ltd. (Abbreviated as “Wuxi Sunket” or “Sunket”)

Please read this installation manual carefully before installation. The operation of a photovoltaic power system requires relevant expertise and the system must be installed and maintained by personnel who have the expertise and who are familiar with its mechanical and electrical requirements. To ensure proper installation of PV module products, the installer must read and understand this manual prior to installation. If any questions, please contact Sunket’s Customer Service Department (info@sunket.com) or your local representative for more details.

2 Sunket PV modules and applications

Sunket's photovoltaic solar modules use a DC power supply that is highly reliable and virtually maintenance-free under light conditions. They are ideal for use in remote power systems, home power systems, renewable energy vehicles, hydroelectric plants, water pumps, communication systems or directly in solar photovoltaic power stations, which can be used with or without batteries and directly on the grid.

This installation manual applies to Sunket’s single- glass mono crystalline series PV module products. The models are shown below.

- 156 cells: SKTxxxM10 (xxx = 560- 605, in increment of 5)
- 144 cells: SKTxxxM10 (xxx = 520- 555, in increment of 5)
- 132 cells: SKTxxxM10 (xxx = 475- 510, in increment of 5)
- 120 cells: SKTxxxM10 (xxx = 430- 465, in increment of 5)
- 108 cells: SKTxxxM10 (xxx = 390- 415, in increment of 5)

Wuxi Sunket New Energy Technology Co.,Ltd.	Conventional Single Glass Module	SUNKET SOLAR
Dominant Sector: Module Technology Platform	Installation and Maintenance Manual	Page: page 5 of 33

96 cells: SKTxxxM10 (xxx = 345- 370, in increment of 5)
84 cells: SKTxxxM10 (xxx = 300- 325, in increment of 5)
72 cells: SKTxxxM10 (xxx = 260- 280, in increment of 5)
60 cells: SKTxxxM10 (xxx = 215- 230, in increment of 5)
48 cells: SKTxxxM10 (xxx = 175- 185, in increment of 5)
42 cells: SKTxxxM10 (xxx = 150- 160, in increment of 5)
36 cells: SKTxxxM10 (xxx = 130- 140, in increment of 5)
30 cells: SKTxxxM10 (xxx = 110- 115, in increment of 5)
26 cells: SKTxxxM10 (xxx = 95- 110, in increment of 5)
18 cells: SKTxxxM10 (xxx = 65- 70, in increment of 5)
16 cells: SKT60M10
14 cells: SKT50M10

156 cells: SKTxxxM6 (xxx = 465- 500, in increment of 5)
144 cells: SKTxxxM6 (xxx = 430- 465, in increment of 5)
132 cells: SKTxxxM6 (xxx = 395- 425, in increment of 5)
120 cells: SKTxxxM6 (xxx = 360- 385, in increment of 5)
108 cells: SKTxxxM6 (xxx = 325- 345, in increment of 5)

The parameters of the above products are detailed in the official catalogue (www.sunket.cn).

The photovoltaic modules described in this manual can only be used on the earth, not in space. When installing in high altitude areas, consider the impact of high altitude on module operation.

3 Warning

Before installing, wiring, operating or maintaining modules, you should read and understand all safety rules. When the battery surface of the module is directly exposed to sunlight or other light sources, direct current (DC) will be generated. No matter whether the module is connected or not, direct contact with the live parts of the module, such as the terminal, may cause casualties.

	<p>Maximum series fuse rating 20A Power production tolerance $\pm 3\%$ This module produces electricity when exposed to light. Follow all applicable safety precautions. Only qualified personnel should install or perform maintenance work on these modules Be aware of dangerous high DC voltage when connecting modules. Do not damage or scratch the rear surface of the modules. Do not handle or install modules when they are wet. Follow the battery manufacturer's recommendations if batteries are used with modules.</p>
---	---

4 Safety instructions

The installer must abide by all the safety instructions and precautions mentioned in

Wuxi Sunket New Energy Technology Co.,Ltd.	Conventional Single Glass Module	SUNKET SOLAR
Dominant Sector: Module Technology Platform	Installation and Maintenance Manual	Page: page 6 of 33

this manual, and at the same time observe the laws or regulations of authorized agencies and other local requirements. Failure to comply with the relevant safety and installation specifications described in this manual, or failure to comply with the laws or regulations of authorized agencies and other local requirements will result in the invalidation of the limited warranty of the purchased modules.

Sunket's Solar PV modules have passed the test of the world's authoritative certification institutes. Please rest assured to use it if it meets the requirements and terms of this manual.

- Before installing the solar photovoltaic power generation system, please contact the relevant local authority to determine the installation permit and inspection requirements that meet the local requirements.
- When designing a photovoltaic system, please be sure to consider the voltage changes under different temperature conditions (please check the temperature coefficient of all photovoltaic modules, when the temperature drops, the variable output voltage of the modules will rise).
- As the condition of photovoltaic power generation is under sunlight, the modules can work normally to generate electricity. Shadow occlusion has a great impact on the load of module power generation. Modules should not be (shadow) occluded (for example, through buildings, chimneys, trees) throughout the year, and partial (shadow) occlusion (for example, through overhead lines, dirt, snow) should also be avoided.
- The modules should be stored in the original packing box before installation. Please protect the package from damage during the transportation and storage of the modules. Do not open it unless the modules arrive at the installation site. Follow the recommended unpacking steps, and be careful during transportation, opening and storage. It is forbidden to drop the packaged modules directly.
- Please ensure correct and proper transportation and installation methods, otherwise the modules may be damaged.

Wuxi Sunket New Energy Technology Co.,Ltd.	Conventional Single Glass Module	SUNKET SOLAR
Dominant Sector: Module Technology Platform	Installation and Maintenance Manual	Page: page 7 of 33

- When stacking modules, do not exceed the maximum number of layers printed on the packing box. Before unpacking, please place the packing box in a ventilated, rain-proof and dry place.
- It is forbidden to stand, climb, walk or jump on the unopened packing box and modules.
- Please do not put any heavy or sharp objects on the front or back of the module at any time to avoid damage to the module and affecting its safety.
- When disassembling the carton, please use disassembly tools and supports to prevent the modules from tilting or falling off. It is forbidden to place the modules in an unreliable support or unfixed environment.
- At any time, it is forbidden to carry modules by pulling the wires or junction boxes. When moving modules, 2 or more people with non-slip gloves should hold modules at the same time; Do not place the modules on the head for transportation; Do not stack the modules for transportation.
- If you need to store modules temporarily, they should be stored in a dry and ventilated environment.
- Before installation, please make sure that all modules are in clean and dry conditions when they are in contact with electrical appliances.
- Do not install any modules when it is raining, snowing or windy.
- Do not install and use modules under the artificial condensing light source.
- Use durable, rust-proof and UV-resistant materials to make the module support structure. Please use the tested, certified and approved support structure.
- When any module is installed on a column, the column and module support structure must be able to withstand local wind and snow loads. Please ensure that the wind and snow loads on the modules do not exceed the maximum load allowed by the design.

Wuxi Sunket New Energy Technology Co.,Ltd.	Conventional Single Glass Module	SUNKET SOLAR
Dominant Sector: Module Technology Platform	Installation and Maintenance Manual	Page: page 8 of 33

- During installation, do not use solar photovoltaic modules with broken glass or damaged backsheet. Such modules cannot be repaired. Once they touch the surface or aluminum frame, it will cause the risk of electric shock. Do not try to disassemble the module, and do not remove or damage the nameplate of the module or any parts on it.
- During installation, it is prohibited to step on or stand on any photovoltaic module, and do not damage or scratch its glass surface.
- Do not use any paint or glue on the glass of the module.
- When the solar photovoltaic module is exposed to sunlight, it will generate electricity, and the electricity generated by the solar photovoltaic system is enough to cause fatal electric shock and burning hazard. Only professionally trained and authorized persons can approach solar photovoltaic modules.
- In order to avoid the risk of electric shock or burning, solar photovoltaic modules can be covered with opaque materials during installation.
- During the installation or maintenance of the photovoltaic system, please do not wear metal rings, watches, earrings, nose rings and other metal materials to avoid damage to the modules and cause electric shock.
- In the case of circuit load, please do not disconnect any electrical connections or unplug any connectors.
- In order to prevent the insulation performance of the modules from degrading, please avoid scratching and cutting any cables or connectors.
- Please use well-insulated tools in accordance with the relevant electrical installation standards. Please keep your children away during transportation and installation of modules, and do not approach the installation site.
- Installation needs to comply with local safety regulations (for example, safety rules, power plant operation regulations), including wires and cables, connectors, charge controllers, inverters, storage batteries, and rechargeable batteries.

Wuxi Sunket New Energy Technology Co.,Ltd.	Conventional Single Glass Module	SUNKET SOLAR
Dominant Sector: Module Technology Platform	Installation and Maintenance Manual	Page: page 9 of 33

- Under the requirements of the National Electrical Code, the maximum system voltage should not be higher than 1000V or 1500V. For the actual situation, please refer to the system voltage specified on the nameplate of the module you are using.
- The current and voltage generated by photovoltaic modules under certain conditions may be higher than those under standard test conditions. If the installation conditions do not meet the requirements of NEC, then you should use the Isc and Voc values to multiply the module by a factor of 1.25 to determine the rated voltage of the module as the standard, strengthen the current carrying capacity of the wire and the rated value of the overcurrent protection device and the control ability of the output end of the connected photovoltaic module.
- Sunket's module design conforms to the international IEC61215 and IEC61730 standards, and its application level is rated as class A. The modules can be used in systems with a current greater than 50V or 240W, and they have passed IEC61730-1 and IEC61730-2 and meet the requirements of safety class II.
- Conforms to the Electrical Code - Part One - Electrical Equipment Safety Standard CSA C22.1-12-2012.
- All modules with exposed conductive parts should be grounded in accordance with the instructions of the installation manual and the requirements of the National Electrical Code of the United States, otherwise it will be regarded as a violation of UL 1703.
- Please consult the local competent authority for the guidance and requirements on installation methods and building fire safety.
- According to the conditions of the roof and mounting brackets, and under the premise of meeting local electrical safety regulations, in order to evaluate the fire rating of the system, it must be covered with a layer of fireproof material suitable for the rating and maintain ventilation.

Wuxi Sunket New Energy Technology Co.,Ltd.	Conventional Single Glass Module	SUNKET SOLAR
Dominant Sector: Module Technology Platform	Installation and Maintenance Manual	Page: page 10 of 33

- Different roof structures and installation methods will affect the fire safety performance of the building. If not properly installed, it may lead to a fire. In order to ensure the fire rating of the roof, the minimum distance between the module frame and the roof surface is 115mm, and appropriate module accessories such as fuses, circuit breakers, and earthed connectors must be used in accordance with local electrical safety regulations.
- Please observe the safety precautions in the module installation manual. Before installing modules on the roof, please ensure that the roof structure is reasonable. In addition, when installing on any roof, the modules must be sealed to prevent water leakage and ensure that the fire rating meets the standards. Dust accumulated on the surface will damage the performance of the module. During installation, the inclination angle should be kept above 10° so that the rain can wash away the dust, and the installation of the module with a too small inclination angle requires more frequent cleaning.
- Please do not operate the operation panel of any equipment near flammable gas.

5 Unloading, transport and storage

5.1 Packing Box sign instructions

Do not discard modules at will, please specifically recycle them.



Do not expose the modules to rain or moisture.



Wuxi Sunket New Energy Technology Co.,Ltd.	Conventional Single Glass Module	SUNKET SOLAR
Dominant Sector: Module Technology Platform	Installation and Maintenance Manual	Page: page 11 of 33

The modules in the carton are fragile, please handle them carefully during transportation.

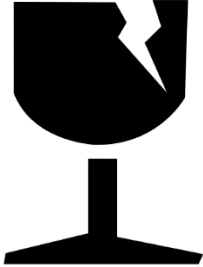

The packaging should be upright during transportation.



When stacking modules, do not exceed the maximum number of layers (2 layers) printed on the outer box.

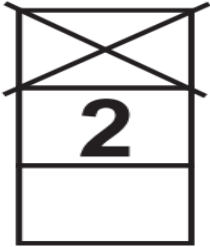

The material can be recycled.

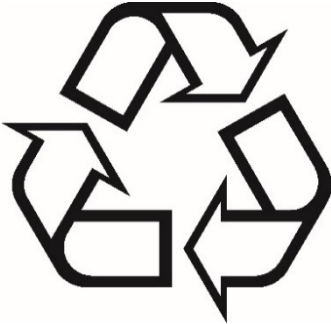

5.2 Unloading Notes

Please use reasonable lifting fixtures and allow a maximum of 2 pallets of modules to be lifted at one time. Before lifting, please make sure that the pallet and carton are not damaged and that the lifting ropes are strong and secure. When lifting is almost on the ground, one of two people should hold the carton gently on a relatively flat position on the project site.

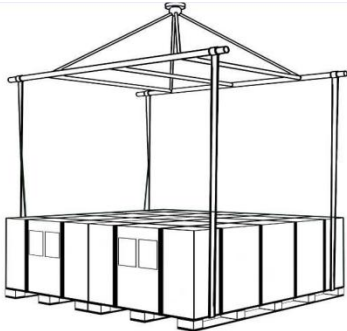

Please use a forklift to unload the modules from the truck.

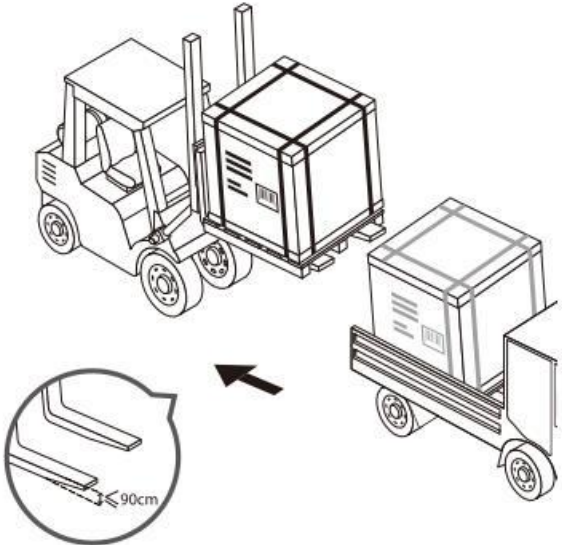

Please place the modules on a level ground.

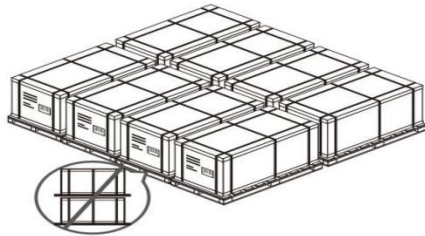

Do not stack modules at the project site.

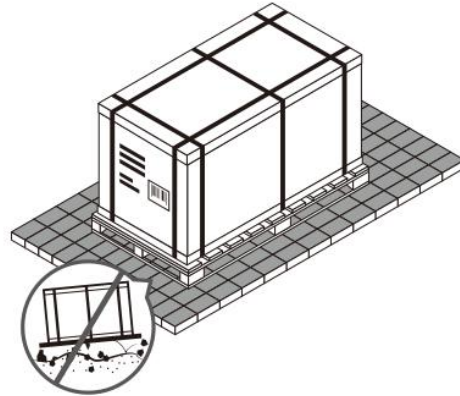

Please put the modules in a ventilated and dry place.

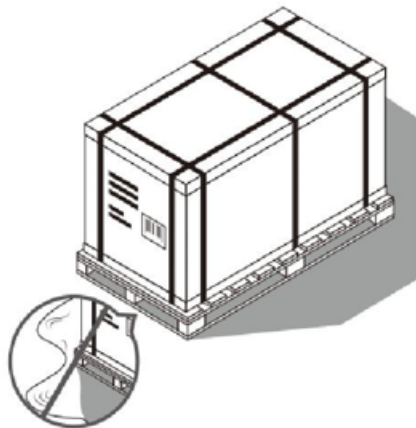

Please use a rain cover to cover the modules to prevent the packing box from getting wet.



5.3 Secondary transportation and precautions

If the modules need to be transported or stored for a long time, please do not remove the original packaging.

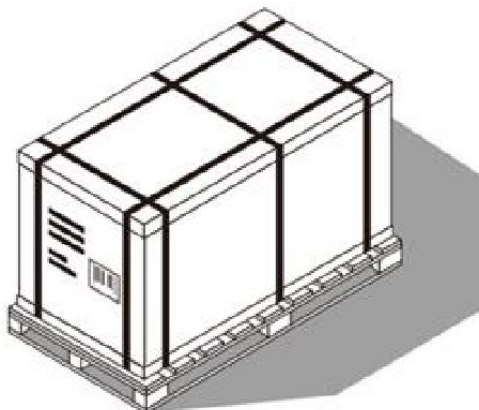

The packaged finished products can be transported by land, sea, or air. During shipping: please secure the packing box to the transportation platform to ensure that the box will not roll over. (Take land transportation as an example).

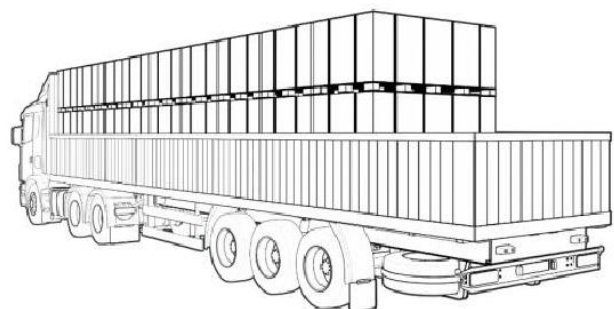

Prohibit the use of tricycles to transfer modules.

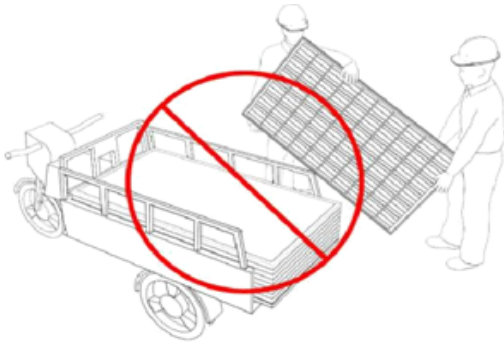

Prohibit the use of ropes to carry the modules.

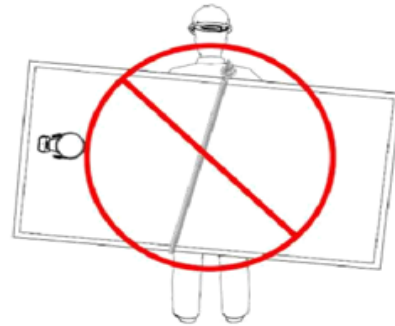

Prohibit carrying modules on your back.



5.4 Storage

- Please do not expose the modules to rain or damp environment. Please store them in a ventilated, rainproof and dry environment.
- Do not remove modules from their original packing box if they are to be transported long distances or stored for long periods of time.
- When storing modules in a warehouse at the project site, please ensure that the storage environment is less than 85% humidity, the temperature range is - 40°C ~ + 50°C, and the modules are statically stacked for 1 box (as shown in Figure 5-1)

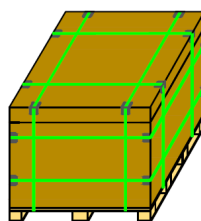

Figure 5-1 Requirements for temporary storage at the installation site

Wuxi Sunket New Energy Technology Co.,Ltd.	Conventional Single Glass Module	SUNKET SOLAR
Dominant Sector: Module Technology Platform	Installation and Maintenance Manual	Page: page 14 of 33

5.5 Module sign instructions

Each module has the following types of labels that provide the following information:

- Nameplate: Product type, nominal power, rated current, rated voltage, open circuit voltage, short circuit current, certification mark, maximum system voltage and other information.
- Current standard: the level classified according to the current value of the module.

To provide customers with clear information on the most effective installation of solar modules, the power is divided into four current levels as follows:

I1: Current Classification 1 I2: Current Classification 2

I3: Current Classification 3 I4: Current Classification 4

- Barcode: Each module has a unique barcode. The barcode used by the Sunket module consists of 14 digits. The current encoding rules are as follows. Take YYMMDDABBCCCCC as an example:
 - ✓ The first to the sixth: YYMMDD represents the date of manufacture;
 - ✓ The seventh: A is the internal identification code;
 - ✓ The eighth to the ninth: BB means production workshop;
 - ✓ The tenth to the fourteenth: CCCCC represents the product manufacturing serial number.

6 Unpacking

- When unpacking outdoors, it is forbidden to do it in the rain. Because the outer packaging carton will be damp and become soft or damaged, the modules in the packing box may be tilted, tipped and damaged, which may also cause injury to the operator.
- In windy conditions, more attention needs to be paid to on-site safety management, especially in a strong wind environment. Sunket does not recommend transporting modules in this environment. The modules that have been unpacked need to be fixed in an appropriate way.

Wuxi Sunket New Energy Technology Co.,Ltd.	Conventional Single Glass Module	SUNKET SOLAR
Dominant Sector: Module Technology Platform	Installation and Maintenance Manual	Page: page 15 of 33

- Please unpack on a flat ground to prevent the packing box from tilting.
- When unpacking, please wear protective gloves to avoid hand injuries and make sure that no fingerprints are left on the glass surface of the module.
- There are module information and unpacking instructions on the outer packing box, please read carefully before unpacking.
- When moving modules, two people are required to work together. It is strictly forbidden to pull the wire or the module junction box.

7 Module Installation

7.1 Environmental conditions and installation address selection

The environmental conditions applicable to the installation of Sunket's solar photovoltaic modules are as follows:

Table 7-1 Module operation and working environment

Number	Environmental conditions	Range
1	Recommended working environment temperature	- 20°C to+50°C.
2	Extreme working environment temperature	- 40°C to +85°C
3	Storage temperature	- 20°C to +50°C
4	Humidity	< 85 RH%

Notes: The working environment temperature is the monthly average maximum temperature and minimum temperature of the installation site. The mechanical load that solar photovoltaic modules can bear is determined by the installation method. When the photovoltaic system is designed, the mechanical load capacity requires a professional system installer to be responsible for the design.

- If you plan to use photovoltaic modules in a place where water damage may occur (humidity: >85RH%), please consult with the local technical support team of Sunket to determine the appropriate installation method or determine whether it can be installed.

Wuxi Sunket New Energy Technology Co.,Ltd.	Conventional Single Glass Module	SUNKET SOLAR
Dominant Sector: Module Technology Platform	Installation and Maintenance Manual	Page: page 16 of 33

- For most places, Sunket’s solar photovoltaic modules should be installed in places that can receive maximum sunlight throughout the year. In the northern hemisphere, the modules are usually installed with the light-receiving face to the south; while in the southern hemisphere, they are usually installed with the light-receiving face to the north.
- When choosing the installation location, avoid areas with trees, buildings or obstacles, because these objects will form shadows on the solar photovoltaic modules, especially in winter when the sun is at the lowest position on the horizon. Shadows will cause the loss of the output power of the solar photovoltaic system. Although the bypass diodes installed in the modules can reduce this loss to a certain extent, do not ignore the factors of the shadow.
- Do not install solar photovoltaic modules near flames or near the flammables and explosives and do not install them in places where there is water immersion or sprinklers.
- The results of salt spray corrosion test of photovoltaic (PV) modules carried out in accordance with the requirements of IEC 61701 show that Sunket’s solar modules can be installed in corrosive salt-alkali areas near offshore or sulfite areas. Modules must not be immersed in water or installed in environments exposed to water (pure water or salt water) for a long time (such as fountains, waves, etc.). If the modules are placed in salt spray (ie, marine environment) or sulfur-containing (ie, sulfur sources, volcanoes, etc.), there is a risk of corrosion.
- The results of “Ammonia Corrosion Test of Photovoltaic (PV) Modules” carried out in accordance with the requirements of IEC62716:2013 show that Sunket’s solar modules can be safely installed in farms, pastures and other environments with heavy ammonia.

7.2 Photovoltaic module installation inclination

- The installation of the solar photovoltaic module string should maintain the same orientation and the same installation angle. Different installation orientations and

installation inclination angles will cause differences in the total amount of light absorbed by different solar photovoltaic module strings, resulting in mismatches in current and voltage, which will reduce the operating efficiency of the system and cause loss of power output.

- When direct sunlight hits solar photovoltaic modules, the maximum power is generated. For those solar photovoltaic modules installed on permanent supports, the power output of modules in winter should be considered when choosing the best installation angle. Ensuring that the modules have sufficient power output in winter will enable the entire solar photovoltaic module system to have sufficient power output for the rest of the year.
- The installation inclination refers to the angle between the solar photovoltaic module and the ground plane, as shown in Figure 7-1.

Figure 7-1 Installation inclination diagram

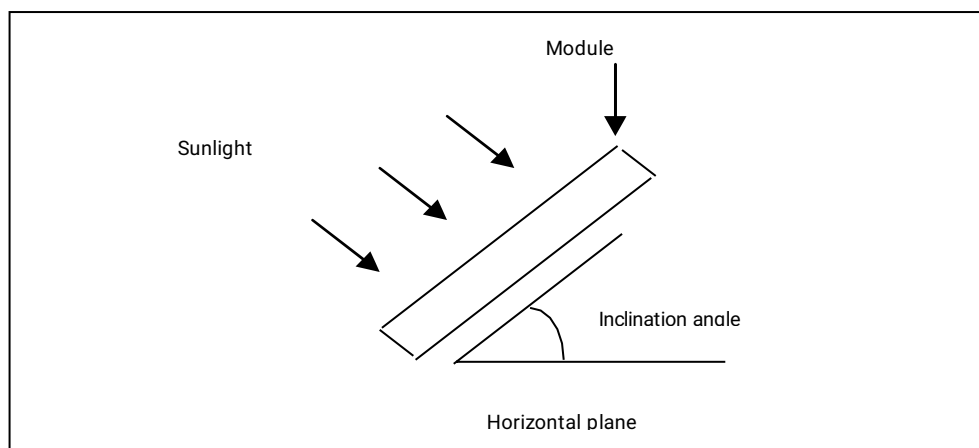

Table 7-2 Recommended installation inclination for the fixing and installation of solar system

Latitude of installation site	Installation inclination
0°~15°	15°
15°~25°	Latitude of the same installation site
25°~30°	Latitude of installation site + 5°
30°~35°	Latitude of installation site + 10°
35°~40°	Latitude of installation site + 15°
40° +	Latitude of installation site + 20°

8 Installation instruction

- During the fixing and installation of Sunket's solar photovoltaic modules you can

Wuxi Sunket New Energy Technology Co.,Ltd.	Conventional Single Glass Module	SUNKET SOLAR
Dominant Sector: Module Technology Platform	Installation and Maintenance Manual	Page: page 18 of 33

adopt bolt fixing method and pressing block fixing method.

- No matter which installation method is adopted, please pay attention to and ensure the following points:
- ✓ In the process of installation, it is recommended to install the modules of the same battery color together;
- ✓ The gap between the module frame and the wall or roof must be at least 115 mm;
- ✓ The minimum gap between two adjacent modules cannot be less than 20 mm;
- ✓ Under no circumstances should the water outlet of the module be blocked;
- ✓ During the system design process, the photovoltaic modules should not bear any load exceeding the maximum design load (such as wind and snow load), and should not bear excessive force due to the thermal expansion of the support structure. According to the climatic conditions of the installation site, a professional system engineer will calculate the load, and then select and design the mounting bracket.

The installation methods listed above are for reference only. The system installer or trained professionals must be responsible for the design, mechanical load calculation, installation, maintenance and safety of the photovoltaic system. Sunket does not provide related installation materials.

Installation tools: screwdrivers, wrenches, stainless steel screws/bolts, pressing blocks, nuts and spring washers, flat washers.

8.1 Bolt fixing method

- Please use corrosion-resistant M8 stainless steel bolts to fix the solar photovoltaic module through the mounting hole on the frame. Sunket recommends you to place solar photovoltaic modules upright when using bolt fixing method, so that the modules will not slip off easily and will be safer to use.

- The aluminum frame of each solar photovoltaic module has 8 or 4 installation holes. In the installation position shown in Table 8-1, the static load that the module can withstand is 5400 pa on the front side and 2400 pa on the back side.
- Please use the M8 anti-corrosion nut and matching screw cap, spring washer and flat washer to fix the solar photovoltaic modules on the bracket. The applied torque of M8 is 16N·m- 20 N·m. M6 should use a torque of 14N·m- 18 N·m.

Table 8-1 Mechanical load of bolt installation

Installation method	Back side≤2400pa; Front side≤5400pa (See Figure 8-1)	
Bolt fixing method	4 bolts fixed	8 bolts fixed

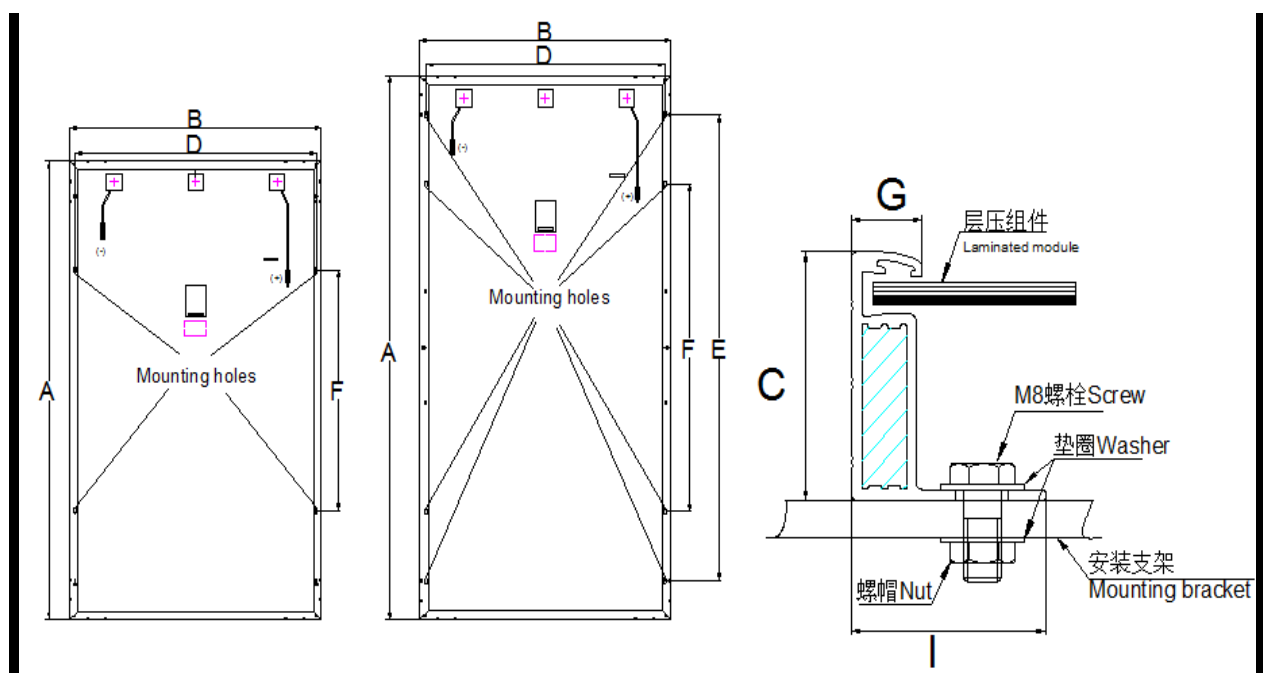

Figure 8-1 Installation location diagram

Table 8-2 Bolt fixing method installation size

Module Type	Module size A*B*C (mm)	Mounting holes D*E/D*F (mm)	Wire length (mm)	Aluminum frame size C*I (mm)
14 cells: SKT50M10	598*400*25	298*366	900mm	25*25
18 cells: SKTxxxM10	598*580*30	957*870	900mm	30*25
26 cells: SKTxxxM10	598*766*30	733*298	900mm	30*25

Wuxi Sunket New Energy Technology Co.,Ltd.	Conventional Single Glass Module Installation and Maintenance Manual	SUNKET SOLAR
Dominant Sector: Module Technology Platform		Page: page 20 of 33

30 cells: SKTxxxM10	970*580*30	547*570	900mm	30*25
36 cells: SKTxxxM10	877*766*30	733*477	900mm	30*25
42 cells: SKTxxxM10	1328*580*30	547*548/1048	900mm	30*25
48 cells: SKTxxxM10	1156*766*30	733*756	900mm	30*25
60 cells: SKTxxxM10	1435*766*30	733*655/1155	1200mm	30*25
72 cells: SKTxxxM10	1164*1134*30	600	1200mm	30*35
84 cells: SKTxxxM10	1350*1134*30	800	1200mm	30*35
96 cells: SKTxxxM10	1536*1134*30	600*1000	1200mm	30*35
108 cells: SKTxxxM10	1722*1134*35	800*1200	1200mm	35*35
120 cells: SKTxxxM10	1909*1134*35	1000*1400	1200mm	35*35
132 cells: SKTxxxM10	2094*1134*35	1100*1500	1200mm	35*35
144 cells: SKTxxxM10	2279*1134*35	1200*1600	1200mm	35*35
156 cells: SKTxxxM10	2464*1134*35	1300*1700	1200mm	35*35

8.2 Pressing block fixing method

- Pressing block fixing method: Use suitable pressing blocks to fix the long or short frame of the solar photovoltaic module. Sunket recommends that you lay the modules horizontally when using pressing blocks to fix modules, so that it is not easy to slip and it is safer.
- Please use a certain number of pressing blocks and M8 bolts to fix the solar photovoltaic modules on the mounting bracket. During installation do not touch the front glass, and do not deform the aluminum frame, and avoid shadowing the solar photovoltaic module. If you choose this pressing block installation method, each solar photovoltaic module needs to be fixed with at least four pressing blocks, and the torque should be 16N·m - 20N·m.

- According to the actual situation of local wind load and snow load, it may be necessary to increase the number of pressing blocks to ensure that the solar photovoltaic modules and systems can bear the corresponding load. One or two pressing blocks can be added to each frame for installation, and the installation position of the added pressing block can be selected between the previous two blocks. Or it can be reinforced with mounting holes, or the length of the pressing block can be increased.

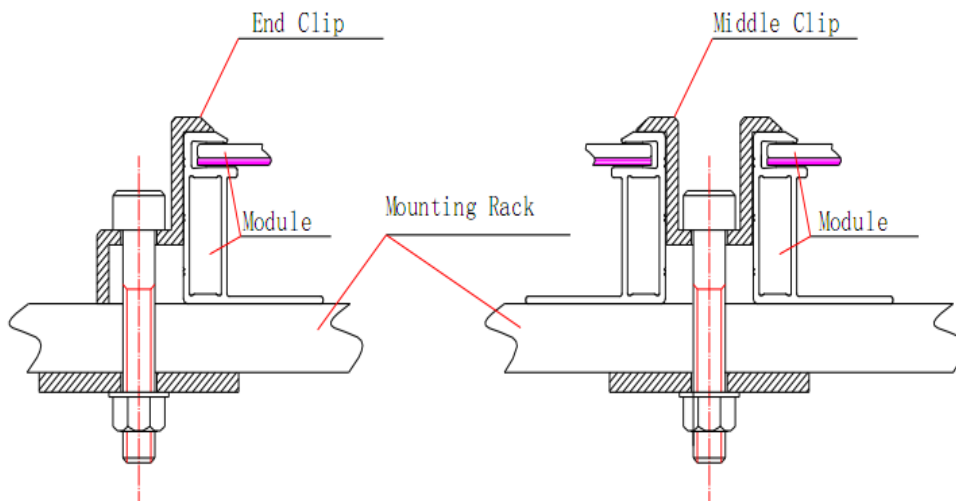

Figure 8-2 Schematic diagram of pressing block installation

Table 8-3 Pressing block installation size

Type	Pressing block on the edge	Pressing block in the middle
Diagram		

Wuxi Sunket New Energy Technology Co.,Ltd.	Conventional Single Glass Module Installation and Maintenance Manual	SUNKET SOLAR
Dominant Sector: Module Technology Platform		Page: page 22 of 33

Specifications	Length*Width*Height 50*35.5*25/30/35/40mm	Length*Width*Height 50 *45*15/25/27mm
	Components M8 bolts, nuts, spring washers, flat washers	

Notes: The pressing block must be kept at least 7mm- 10mm with the module frame (not exceeding dimension G in Figure 8- 1, that is, not exceeding 10mm).

According to the actual situation of local wind load and snow load, the following two methods are recommended for the installation of module pressing block installation method.

- Pressing block fixing method 1

Table 8- 4 Size of Pressing block fixing method 1

Pressing block fixing method 1 (see Table 8- 3)			
Mechanical load		2400Pa	5400Pa
Module Type	Length width (A x B)	Location R1	Between R1 and S1
14 cells: SKT50M10	598*400*25	199	248
18 cells: SKTxxxM10	598*580*30	199	249
26 cells: SKTxxxM10	598*766*30	198	249
30 cells: SKTxxxM10	970*580*30	199	248
36 cells: SKTxxxM10	877*766*30	199	249
42 cells: SKTxxxM10	1328*580*30	199	248
48 cells: SKTxxxM10	1156*766*30	199	249
60 cells: SKTxxxM10	1435*766*30	199	248
72 cells: SKTxxxM10	1164*1134*30	199	249
84 cells: SKTxxxM10	1350*1134*30	199	249
96 cells: SKTxxxM10	1536*1134*30	199	249
108 cells: SKTxxxM10	1722*1134*35	199	249
120 cells: SKTxxxM10	1909*1134*35	199	249
132 cells: SKTxxxM10	2094*1134*35	199	249
144 cells: SKTxxxM10	2279*1134*35	199	249
156 cells: SKTxxxM10	2464*1134*35	199	249

Notes: The length of the pressing block is 50mm; the thickness is $\geq 3\text{mm}$; each module needs at least 4 blocks. When reinforcement is needed, pressing blocks can be added. The torque should be 16N.m - 20N.m. The installation position tolerance of each pressing block is $\pm 25\text{mm}$.

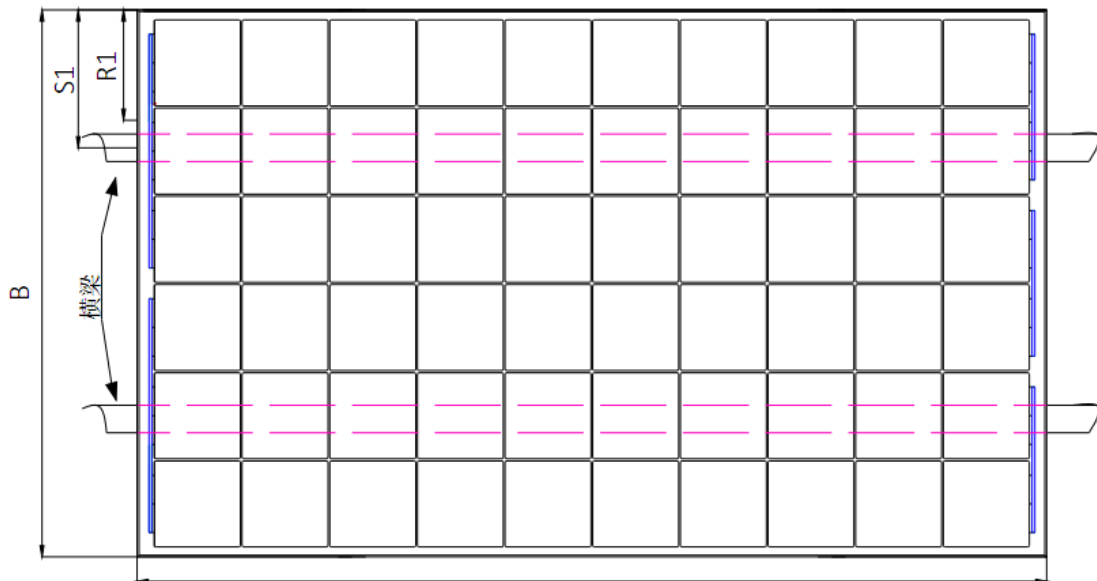

Figure 8- 3 Pressing block fixing method 1

● Pressing block fixing method 2

Table 8- 5 Installation size of pressing block fixing method 2

Pressing block fixing method 2 (See Table 8- 4)			
Mechanical load		2400Pa	5400Pa
Module Type	Length x width (A x B)	Location R2	Location S2
14 cells: SKT50M10	598*400*25	330	413
18 cells: SKTxxxM10	598*580*30	331	414
26 cells: SKTxxxM10	598*766*30	333	416
30 cells: SKTxxxM10	970*580*30	391	489
36 cells: SKTxxxM10	877*766*30	396	495
42 cells: SKTxxxM10	1328*580*30	337	421
48 cells: SKTxxxM10	1156*766*30	338	423
60 cells: SKTxxxM10	1435*766*30	402	503
72 cells: SKTxxxM10	1164*1134*30	403	503
84 cells: SKTxxxM10	1350*1134*30	325	406
96 cells: SKTxxxM10	1536*1134*30	388	486
108 cells: SKTxxxM10	1722*1134*35	370	463
120 cells: SKTxxxM10	1909*1134*35	435	544
132 cells: SKTxxxM10	2094*1134*35	435	544

144 cells: SKTxxxM10	2279*1134*35	435	544
156 cells: SKTxxxM10	2464*1134*35	435	544

Notes: The length of the pressing block is 50mm; the thickness is ≥ 3 mm; each module needs at least 4 blocks. When reinforcement is needed, pressing blocks can be added. The torque should be 16N.m - 20N.m. The installation position tolerance of each pressing block is ± 25 mm.

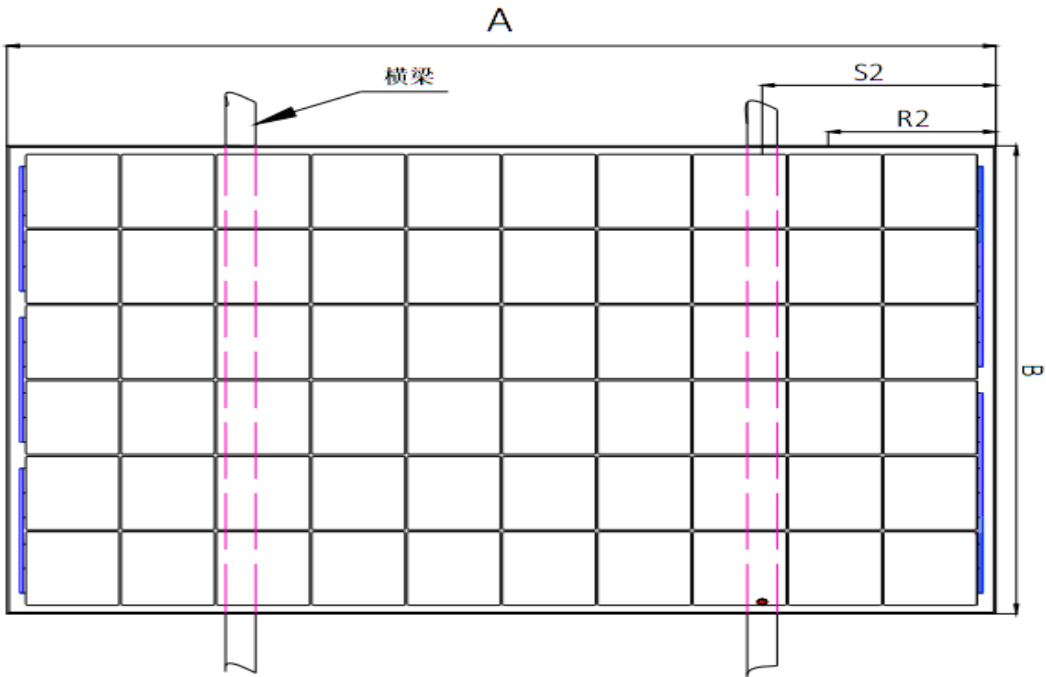

Figure 8- 4 Pressing block fixing method 2

For the above two pressing block installation methods, please choose the long-side installation first. Other methods need to be confirmed with the Sunket’s professional team. System installers or trained professionals must be responsible for the design, mechanical load calculation, installation, and maintenance of the photovoltaic system.

8.3 Connection Method of split junction box assembly cable wires (recommended connection)

The schematic diagram of the recommended vertical installation connection scheme is as follows (need to extend the cable):

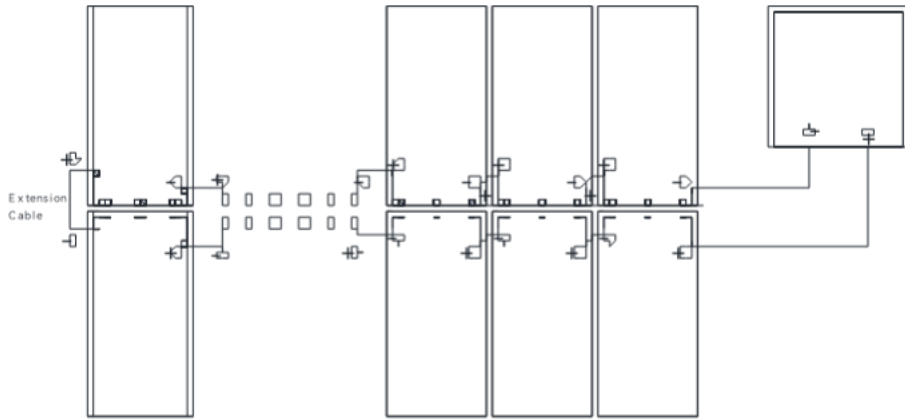

Figure 8-5 Vertical installation of the junction box at the edge

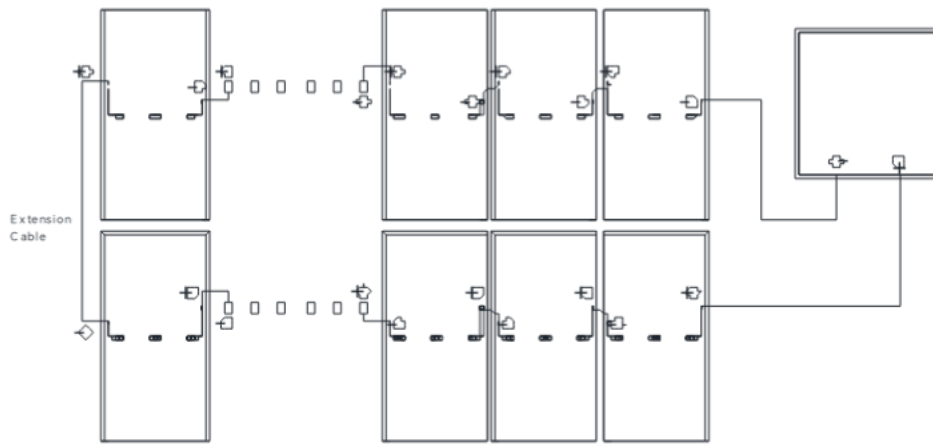

Figure 8-6 Vertical installation of junction box in the middle

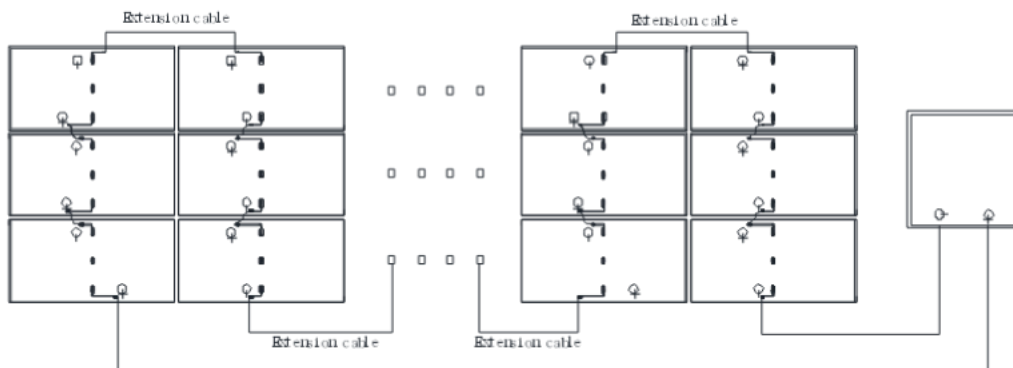

Figure 8-7 Horizontal installation of the junction box in the middle

Note for installation: Pay attention to the direction of the wire when installing the module, and connect it along the direction of the wire to avoid bending of the wire.

Wuxi Sunket New Energy Technology Co.,Ltd.	Conventional Single Glass Module	SUNKET SOLAR
Dominant Sector: Module Technology Platform	Installation and Maintenance Manual	Page: page 26 of 33

9 Electrical installation and connection

- The direct current (DC) generated by the photovoltaic system can be converted into alternating current (AC) and connected to the public grid. Different regions may have different policies, laws and regulations to stipulate the installation requirements and grid connection requirements of photovoltaic systems. Therefore, please comply with local policies, laws and regulations during the design, installation and grid connection of photovoltaic systems.
- Photovoltaic modules can be connected in series and in parallel to obtain different current and voltage outputs. Before electrical connection and installation, please read this installation manual carefully, and design and connect according to the current and voltage required by the customer. Before connecting, make sure that the connecting part is free from corrosion, and keep it clean and dry.
- In order to ensure the normal operation of the system, please make sure that the polarity of the cable is correct when connecting modules or connecting loads. If the modules are not connected correctly, the bypass diode and junction box may be damaged. PV modules can be connected in series (Figure 9-1), parallel (Figure 9-2), and series-parallel (Figure 9-3). The number of modules in series and parallel should be designed reasonably according to the system configuration. At the same time, please note that if the number in parallel is ≥ 2 strings, there must be an overcurrent protection device on each string of modules.

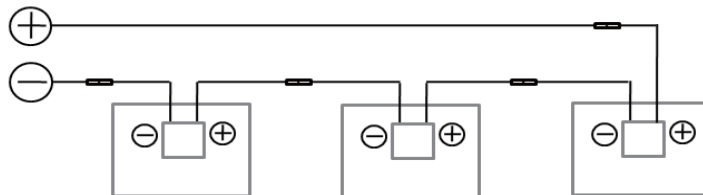

Figure 9-1 Series connection

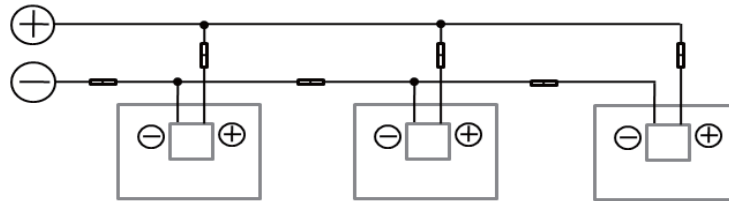

Figure 9- 2 Parallel connection

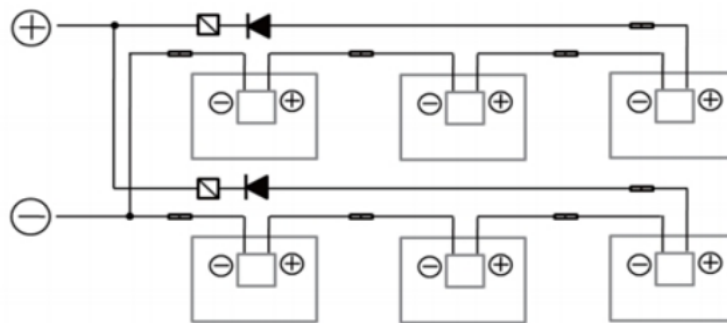

Figure 9- 3 Series-parallel connection

- Different types of module products cannot be connected in series. The series connected module products must ensure the consistency of their currents. The voltage of the module string cannot exceed the allowable module system voltage value, which can be found on the nameplate or specification of modules.
- The maximum number of modules connected in series depends on the system design, the type of frequency converter used and the environmental conditions. Normally, the maximum number of solar photovoltaic modules connected in series (N) can be calculated by dividing the maximum voltage of the system by the open circuit voltage of the relevant solar photovoltaic modules. However, when designing a solar photovoltaic system, it must be considered that the voltage of the solar photovoltaic module changes with temperature changes. Taking into account the voltage increase caused by the temperature drop in the extreme environment in winter, the maximum number of solar photovoltaic modules connected in series can be calculated using the following formula:

Tabla 9- 1 Calculation of the maximum number in series

Formula	Maximum system voltage $V \geq N \times V_{oc} \times [1 + \beta \times (T_{min} - 25)]$		
V	Maximum system voltage		
N	Maximum number of modules that can be connected in series		
V_{oc}	Open circuit voltage of the module under STC conditions (please check the label or specifications of the module)		
β	Temperature coefficient of the open circuit voltage of the module (please refer to the specifications of the module)		
T_{min}	The lowest ambient temperature of the module installation site		
60/120pcd 1000V module	Recommended maximum number of solar photovoltaic modules in series $N \leq 22$	60/120pcd 1500V module	Recommended maximum number of solar photovoltaic modules in series $N \leq 33$
72/144pcd 1000V module	Recommended maximum number of solar photovoltaic modules in series $N \leq 18$	72/144pcd 1500V module	Recommended maximum number of solar photovoltaic modules in series $N \leq 28$

Note: If the number of parallel connections is ≥ 2 strings, there must be an overcurrent protective device on each string of modules.

- If one set of arrays is connected to another with the opposite polarity, it will cause irreparable damage to the product. Before connecting in parallel, be sure to confirm the voltage and polarity of each column. If the measurement finds that the polarity between the columns is reversed or the voltage difference is greater than 10V, check the structural configuration before making the connection.
- Before wiring the modules, make sure that the contact points are corrosion-resistant, clean and dry; if the positive and negative poles of a module string are reversed, irreparable damage may be caused.
- For relatively large installations, Sunket recommends you to use lightning protection to comply with local requirements and regulations.
- Each of Sunket's solar photovoltaic modules has two standard PV conductor cables that can withstand a temperature of 90°C and are resistant to sunlight. The cross-sectional area of its conductive core is 4mm² or 12AWG, and the outer diameter of the conductive wire is 4mm to 12mm. Each wire end has a plug-and-play connector. All other cables used to connect to the DC system should have similar (or higher) specifications. At the same time, it has appropriate insulation performance to

Wuxi Sunket New Energy Technology Co.,Ltd.	Conventional Single Glass Module	SUNKET SOLAR
Dominant Sector: Module Technology Platform	Installation and Maintenance Manual	Page: page 29 of 33

withstand the maximum system open circuit voltage (such as TUV 2PFG1169 or EN50618 (H1Z2Z2- K) approved). The company Wuxi Sunket requires all wiring and electrical connections to comply with the electrical regulations of the countries where the photovoltaic system is installed.

- When selecting a cable, the minimum current-carrying capacity of the cable can be calculated by the following formula.

Minimum current carrying capacity of cable = $1.25 \times I_{sc} \times N_p$

I_{sc} : Short-circuit current of photovoltaic modules (Unit: A)

N_p : The number of modules or module strings connected in parallel

- Please clean up or sort out the excess cables, Sunket recommends that all cables be routed in appropriate pipes and away from places where water is easy to accumulate.
- Sunket recommends the use of lightning protection devices that comply with local laws and regulations and electrical regulations.

9.1 Bypass Diode:

- If a part of the solar photovoltaic module is blocked by shadows, this will cause the relevant solar cells to form a reverse voltage, and the current of the other unaffected cell strings in the solar photovoltaic module or other modules in the system will forcefully pass through the shielding part, resulting in power loss and heating the affected cells. When the diode is bypassed in parallel in the solar photovoltaic module, the current in the system will flow directly through the diode, thereby bypassing the shaded part of the solar photovoltaic module, and minimizing the heat generation and power loss of the solar photovoltaic module.
- Sunket's solar photovoltaic modules are equipped with bypass diodes in the junction box, and each module has 3 diodes. Diode types are such as 15QS045 / 20SQ045 / SBRB2045S / SMBRB3045S / GF2045MG / SBRB3050TS / MSB3050T3A / MSB3050T3B (Twinsel junction box PV-SY001/PV-SY005/ PV-SY015/PV-RS006/

Wuxi Sunket New Energy Technology Co.,Ltd.	Conventional Single Glass Module	SUNKET SOLAR
Dominant Sector: Module Technology Platform	Installation and Maintenance Manual	Page: page 30 of 33

PV- SY017). Please do not try to open the junction box to replace the diode, even when there is a problem with the diode, these tasks should be done by professionals.

10 Grounding

- All solar photovoltaic module frames and mounting brackets must be properly grounded in accordance with the corresponding “National Electrical Code”.
- Please connect the frame of the photovoltaic module and all metal components continuously by using a suitable grounding conductor to achieve correct grounding. The grounding wire can be copper, copper alloy that can be used as wires or other materials used as electrical conductors that meet the requirements of the corresponding “National Electrical Code”. It is recommended to use 4- 14mm² copper wire (AWG 6- 12) as the grounding wire. The grounding hole of the module has a grounding mark “ \perp ”. The ground wire must also be connected to the earth through a suitable ground electrode. All conductive connection points must be firmly connected.
- The Sunket’s grounding hole is designed on the aluminum alloy frame on the back of the photovoltaic module with a diameter of 4mm. Please use a separate ground wire and related accessories to connect the aluminum alloy frame of the solar photovoltaic module and connect the ground wire to the ground. It is recommended to use M4 x 12mm grounding bolts with M4 nuts, star washers and flat washers to ensure that the modules are firmly grounded. You can find the corresponding product drawings in the Sunket’s module product manual to understand the detailed product grounding hole quantity, size and location. The grounding fixing should use a torque of 4N· m - 8N· m.

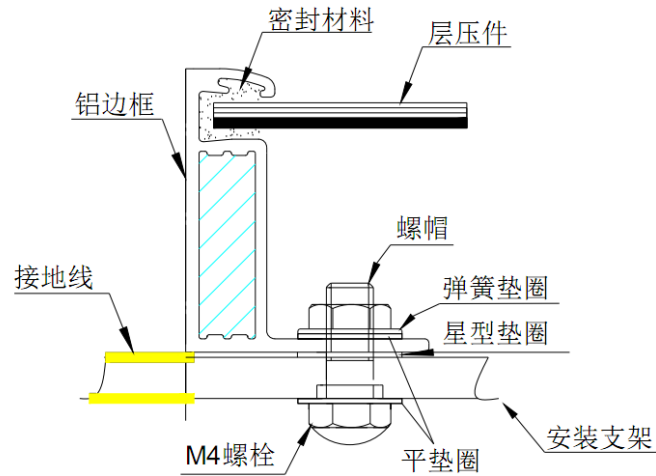

Figure 10- 1 Grounding diagram

When grounding, each module can be directly grounded, or it can be grounded after the modules are connected in series or in parallel. When adopting the latter grounding method, it is recommended that the maximum number of modules connected in parallel should not exceed four, and the maximum number of series connected modules should not exceed eight.

In addition to using grounding holes for grounding, you can also choose the following methods for grounding:

- ✓ Use unused mounting holes for grounding
- ✓ Other dedicated grounding devices

No matter which grounding method is adopted, all the grounding electrical contacts with the aluminum alloy frame of the photovoltaic module need to penetrate the anodized coating of the aluminum frame. When using dedicated grounding devices and other third-party grounding devices, you need to ensure that these grounding devices are reliable, and pass professional certification. Please comply with the grounding device manufacturer's use regulations during installation.

11 Module inspection and maintenance

In order to ensure that the installed photovoltaic system can be used for a long time and maximize the power output performance of the modules, the installed photovoltaic

Wuxi Sunket New Energy Technology Co.,Ltd.	Conventional Single Glass Module	SUNKET SOLAR
Dominant Sector: Module Technology Platform	Installation and Maintenance Manual	Page: page 32 of 33

modules need to be inspected and maintained regularly. The inspection and maintenance of the modules in the photovoltaic array requires personnel who have received professional photovoltaic system maintenance training and obtained relevant qualifications and authorizations.

11.1 Module appearance check and replacement

- The photovoltaic modules installed in the photovoltaic array should be checked regularly for damage. If it is found that the PV modules have functional and safety failures due to the following factors, the modules of the same type should be replaced immediately:
 - ✓ The photovoltaic module has broken glass and scorched backsheet;
 - ✓ There are bubbles in the photovoltaic module that form a communication channel with the edge of the module or any circuit;
 - ✓ The junction box of the photovoltaic module is deformed, twisted, damaged, cracked or burned, and the wiring terminal cannot be connected well.
- The replacement solar photovoltaic module must ensure that the solar photovoltaic module type is the same. Please do not directly touch the live wires and connectors. When you need to touch them, please use appropriate safety devices (insulated tools, insulated gloves, etc.).
- The live warning signs on the photovoltaic modules must not be lost.
- It is recommended to check the electrical, grounding and mechanical connections every 6 months to ensure that they are clean and safe, free from damage or rust; Please check whether the installation parts have been tightened; Please check all cables and ensure that the connectors are firmly tightened. Please use photovoltaic modules with metal frame, and the frame and bracket should be well combined.
- Please check whether there is any foreign matter on the surface of the photovoltaic module and whether it is blocked.
- When repairing solar photovoltaic modules, please cover the surface of solar photovoltaic modules with opaque materials to prevent electric shock. Solar

Wuxi Sunket New Energy Technology Co.,Ltd.	Conventional Single Glass Module	SUNKET SOLAR
Dominant Sector: Module Technology Platform	Installation and Maintenance Manual	Page: page 33 of 33

photovoltaic modules will generate high voltage when exposed to sunlight. Please pay attention to safety when repairing, and repairs must be carried out by professionals.

- When the irradiance is not less than $200\text{W}/\text{m}^2$, if the voltage of the terminal is different from the rated value by more than 5%, it means that the module is not connected properly.
- Please follow the maintenance instructions for all components used in the photovoltaic system, such as brackets, charging rectifiers, inverters, batteries, and lightning protection systems.
- Warning: For any electrical maintenance, the photovoltaic system must be shut down first. Improper system maintenance may cause fatal dangers such as electric shock and burning.

11.2 Cleaning

The power output of the module is related to the incident light intensity. The accumulation of dust on the glass surface of the module will affect the incident light intensity and reduce the energy output of the module. Therefore, the surface of the photovoltaic module should be kept clean, and the cleaning should be done at least once a year or more frequently according to the degree of pollution.

Warning: The cleaning of the modules should be carried out by trained personnel. The staff should wear rubber gloves and working boots, and should be able to withstand a DC working voltage of not less than 2000V.

- Please use dry or damp, soft and clean cloth and sponge to wipe photovoltaic modules. It is strictly forbidden to use corrosive solvents or hard objects to wipe photovoltaic modules. When cleaning with pressure water flow, the water pressure on the glass surface of the module shall not exceed 700 kPa, and the module is strictly prohibited to withstand additional external force; however, do not put any module directly in the water. If necessary, please clean with isopropyl alcohol (IPA) in

Wuxi Sunket New Energy Technology Co.,Ltd.	Conventional Single Glass Module	SUNKET SOLAR
Dominant Sector: Module Technology Platform	Installation and Maintenance Manual	Page: page 34 of 33

accordance with the safety instructions, and ensure that no IPA flows into the gap between the edge of the module and the module frame.

- The photovoltaic modules should be cleaned when the irradiance is lower than 200W/m². It is not advisable to use liquids with large temperature differences to clean the modules. If the temperature of the solar modules is high during the day, cold water is used to clean the photovoltaic modules to prevent damage to solar photovoltaic modules.
- When cleaning photovoltaic modules, please do not do it under weather conditions with wind greater than level 4, heavy rain or heavy snow.
- Under normal circumstances, the back of the module does not need to be cleaned; however, when it is deemed necessary to clean it, all sharp objects that may cause damage or penetrate the backing material should be avoided.
- Requirements for water quality during cleaning:
 - ✓ PH: 5~7; Chloride or salt content: 0- 3,000 mg/L; Turbidity: 0- 30 NTU;
 - ✓ Conductivity: 1500 ~ 3000 μs/cm ; Total dissolved solids: ≤1000 mg/L ; Water hardness: 0- 40 mg/L ;
 - ✓ Non- alkaline water must be used, and demineralized water should be used when conditions are available.
- After cleaning, the modules need to be inspected.
 - ✓ Visually check whether the overall appearance of the modules is clean, bright and stain- free;
 - ✓ Sampling to check whether there is dust accumulation on the surface of the modules;
 - ✓ Please check if there are obvious scratch marks on the surface of the modules;
 - ✓ Please check if there is human- induced rupture on the surface of the modules;
 - ✓ After cleaning, please check if the module bracket is tilted or bent;

Wuxi Sunket New Energy Technology Co.,Ltd.	Conventional Single Glass Module	SUNKET SOLAR
Dominant Sector: Module Technology Platform	Installation and Maintenance Manual	Page: page 35 of 33

- ✓ After cleaning, please check if the wiring terminals of the modules are loose or fall off;
- ✓ It is necessary to complete the written record after cleaning.

12 Troubleshooting

If the photovoltaic system fails to work normally after installation, please notify the installer immediately. It is recommended to perform preventive inspections every 6 months and do not replace components of modules without authorization. If electrical or mechanical performance inspection and maintenance are required, it is necessary to have qualified and professionally trained professionals perform the operation to avoid occurrence electric shock or casualties.

13 Disclaimer

As the installation, operation and use of Sunket's solar photovoltaic modules are beyond the company's control, those improper installation, operation, use and maintenance caused power loss, solar photovoltaic module damage, casualties or additional costs, Sunket are not responsible for it.

Sunket is not responsible for any infringement of the patent rights of third parties or any other rights arising from the use of solar photovoltaic modules.

Sunket reserves the right to update products, parameters, product specifications, installation manuals and other documents without prior declaration.

The information in this installation and service manual is derived from knowledge and experience, and such information and suggestions do not constitute any guarantee.

This manual is only available in electronic version. If you need a paper version, please call the customer service hotline 400-1008-703. If there is an ambiguity between Chinese and English in this manual, the Chinese version shall prevail. Sunket reserves the right to interpret this installation manual.